

TORS series – Transformer Oil Regeneration System

Regeneration systems typically remove the by-products of aging from used transformer oil. By-products that are known as secondary contamination are created as a result of natural aging of a transformer in service coupled with inadequate maintenance regimens. There are traditionally two approaches to the removal of these contaminants, either approach will result in the used oil being restored to 'as new'.

Comparison of Reactivation vs. Single-use Fullers Earth systems used under identical conditions

	Reactivation	Single-use
Method	Process, saturate, reactivate, process, saturate, reactivate, etc	Process, saturate, dispose
Disposal	Regular landfill	Specialist
Times used	300 - 500	1
Oil loss	< 0.4%	> 5%
Amount required to process 2.5 Mlitre	1 ton	100 ton
Lifetime yield	2500 litre/kg	25 litre/kg
Change-out frequency	4 years	1 week

Mobile systems are usually limited by the prevailing road transport regulations and may limit systems to 44 ton in weight or 53-foot in length. Practically, this tends to limit the system flow rates to around 10,000 litres per hour.



Above: TORS-6000 at sub-station

Typical regenerated oil specification

Guaranteed parameters achieved after regeneration with TORS series

Characteristic	Unit	After regeneration
Acidity	mg KOH/g oil	<0.01
Appearance		Sparkling
Colour	L	<0.5
Corrosive sulphur		Absent
Dielectric breakdown	kV	>70
Gas content	%	<0.1
IFT	dynes/cm	>40
Moisture content	ppm	<5
Oxidation - acidity	mg KOH/g oil	<0.2
Oxidation - sludge	%	<0.03
Particle size	μ	<2
Tan delta @ 90°C		<0.001

Benefits of regenerating oil

- Life extension of a limited resource** – Regeneration technology has a long history which shows that recycled oil is as good as, if not better than new. The same oil that has been aged, regenerated, aged and regenerated 6 times shows no

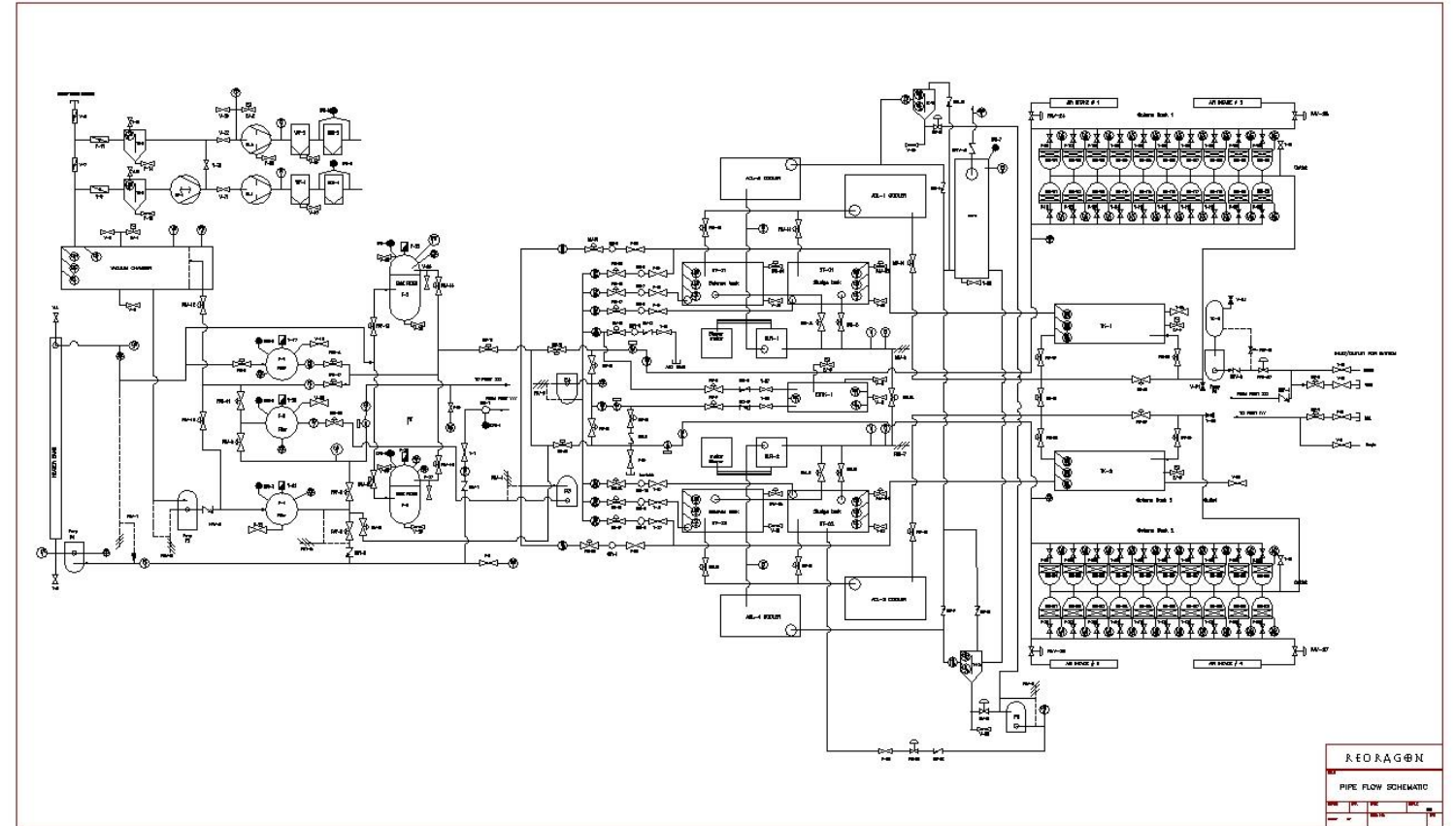

The TORS series allows for customization of the reactivation type of regeneration system. Larger systems are ideally suited to unattended tank farm operation, where there is practically no limit to the number of columns used and hence volume processed.



Above: TORS-6000, at underground generating station

decrease in efficiency showing an effective lifetime for oil-in-use of over 100 years.*

- Economically advantageous** – The price of purchasing regenerated oil is typically less than 80% of new oil and can be as low as 50%. Ancillary savings increment when considering there is no downtime when reclaiming on energised equipment. Replacement with new oil and hot oil flush requires equipment switch off.
- Control of strategic asset is retained** – Oil in use is an asset. Use of regeneration technology removes dependence on oil companies to deliver replacement supplies and isolates from wildly fluctuating external market prices.

*From unpublished work by George Hodgson and ESKOM, South Africa, 2001



Above: Various stages of regenerated transformer oil

TORS series – Transformer Oil Regeneration System



- Removal of corrosive sulfur –**

Lower quality transformer oil contains DBDS (Dibenzyl Disulfide) as corrosive sulfur. Corrosive sulfur has been identified as the cause of several transformer failures in recent years. Fully regenerating using the TORS removes DBDS and obviates the requirement for passivating the oil, reducing oil maintenance costs and providing peace of mind.

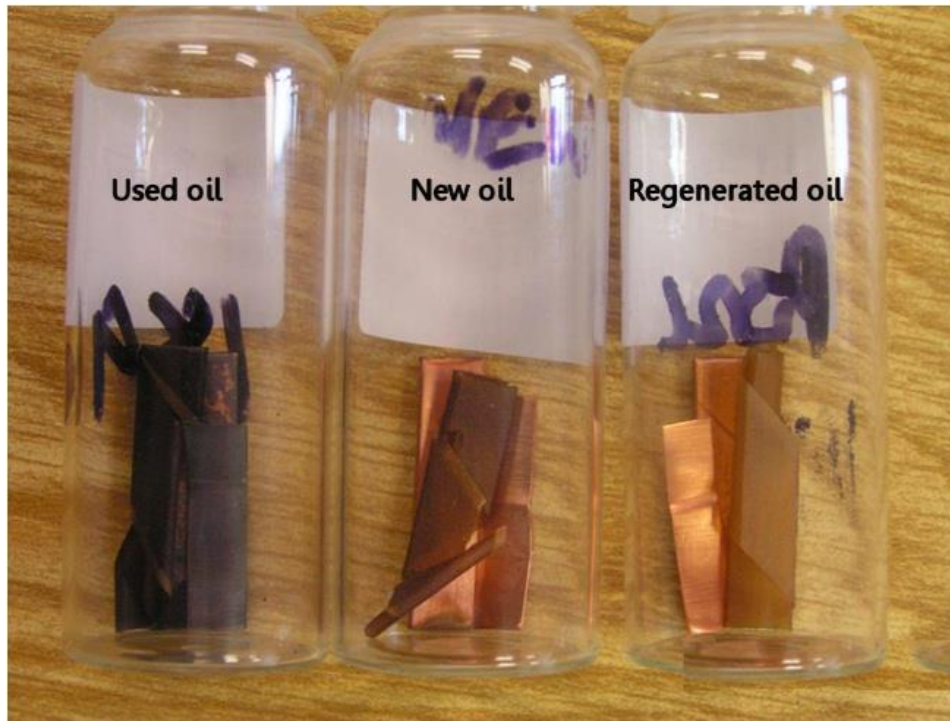

Above: Corrosive sulfur tests on used, new and regenerated oils per ASTM 1275 Method B

- Processing on energized transformers –**

The TORS units are designed to operate on energized transformers as effectively as on un-energized transformers. There is no loss of income, as there would be for an oil change-out, if the transformer is processed energized. The additional advantage of this process is that the transformer core is treated at the same time and the transformer can be completely de-sludged – a benefit not accrued with retro-filling.

Typical TORS unit specification – a guide only and subject to change

Model	Flow rate US GPH nominal	Oil heater kW	Vacuum pump m ³ h ⁻¹ (CFM)	Roots booster m ³ h ⁻¹ (CFM)	Chamber inches, ϕ	Oil pumps kW (HP)	Supply required Amps at 380V (480V)
TORS-100	25	3	6 (4)	N/A	14	4 (3)	25A (20A)
TORS-500	125	9	25 (20)	N/A	14	4 (3)	40A (32A)
TORS-1000	250	16	63 (41)	280 (200)	20	5 (6)	60A (50A)
TORS-1500	400	32	165 (117)	560 (400)	20	5 (6)	90A (80A)
TORS-2000	500	32	200 (141)	765(540)	20	5 (6)	120A (100A)
TORS-3000	800	48	255 (180)	1000 (705)	20	5 (6)	160A (130A)
TORS-4000	1000	64	300 (212)	2000 (1410)	20	7(9)	200A (160A)
TORS-5000	1250	80	400 (330)	2000 (1410)	25	7(9)	250A (200A)
TORS-6000	1500	96	500 (413)	2600 (1835)	25	7 (9)	300A (250A)
TORS-10000	2500	160	1000 (704)	3825 (2700)	30	11 (15)	400A (320A)

Model	No. of columns	Inlet size mm (in)	Outlet size mm (in)	Vacuum line mm (in)	Length mm (in)	Width mm (in)	Height mm (in)	Weight kg (lb)
TORS-100	2 x 1	12 (1/2)	12 (1/2)	12 (1/2)	3650 (144)	1800 (72)	2450 (96)	3000 (6600)
TORS-500	2 x 2	19 (3/4)	19 (3/4)	25 (1)	4500 (180)	2100 (84)	2450 (96)	4800 (10500)
TORS-1000	2 x 3	25 (1)	25 (1)	40 (1-1/2)	4500 (180)	2450 (96)	2450 (96)	6400 (14000)
TORS-1500	2 x 5	25 (1)	25 (1)	50 (2)	6000 (240)	2450 (96)	2450 (96)	7500 (16500)
TORS-2000	2 x 6	40 (1-1/2)	40 (1-1/2)	50 (2)	6000 (240)	2450 (96)	2450 (96)	8600 (18900)
TORS-3000	2 x 9	40 (1-1/2)	40 (1-1/2)	50 (2)	7600 (300)	2450 (96)	2450 (96)	9500 (20900)
TORS-4000	2 x 12	40 (1-1/2)	40 (1-1/2)	50 (2)	9100 (360)	2450 (96)	2450 (96)	10400 (22800)
TORS-5000	2 x 15	40 (1-1/2)	40 (1-1/2)	75 (3)	9100 (360)	2450 (96)	2450 (96)	11600 (25500)
TORS-6000	2 x 18	40 (1-1/2)	40 (1-1/2)	75 (3)	9100 (360)	2450 (96)	2450 (96)	12700 (28000)
TORS-10000	2 x 30	50 (2)	50 (2)	150 (6)	12200 (480)	2450 (96)	2450 (96)	17000 (37400)

System Add-ons

- DBPC blend-back modules
- Equipped onboard laboratory
- Remote control and monitoring
- Personnel amenities
- Selection of inline instrumentation
- Custom SCADA and HMI interfaces
- Mobile options including semi-trailer, canvas-side trailer, tagalong trailer, sea container, castors.



Left: TORS-4000 in canvas-side trailer



Right: TORS-2000, skid-mounted

2017 Copyright Redragon